

14-Bit High Speed Magnetic Encoder IC Series

1. Features

- 14-bit resolution rotary encoder
- Support maximum speed of 200K rpm
- Angular linear error $<\pm 0.35^\circ$
- Power output withstand voltage $\geq 24V$, $< -18V$
- Support multiple interface options:
 - ABZ+PWM
 - SPI protocol output
- Supports 3.3V and 5.0V operating voltage applications
- SC60214 supports 3 times of zero adjustment
- Diagnostic functions: wire breakage, overcurrent, undervoltage/overvoltage, overtemperature
- Operating temperature range: -40°C to 150°C
- Package type: SOP-8

2. Applications

- Absolute angular position sensor
- Robotic joint control
- Contactless knobs/Potentiometers
- Mouse scroll wheel encoding
- Stage lighting pan/Tilt position feedback

3. Description

SC6021X is a non-contact, high-speed, high-precision magnetic encoder chip series with a built-in Hall induction point matrix in the center of the chip, which generates sine and cosine position signals by sensing a pair of pole magnets above the chip. The analog-to-digital conversion circuit inside the chip samples the amplified sine and cosine signals, the DSP circuit performs angle calculations, and finally outputs various position signals. The SC6021X has a resolution of 14-bit and supports up to 200K rpm.

SC60214 the chip is calibrated to zero point through an external programmer, which needs to be phased in at the zero position of the motor, and then the encoder chip is calibrated. The incremental output interface outputs up to 2048 lines through the A, B, and Z pins, providing products with different resolutions according to actual usage needs.

SC60218 provides 14-bit SPI protocol output.

SC6021X is available in an 8-pin SOP-8 package, matt tin plated, and halogen-free green material to meet environmental protection requirements.

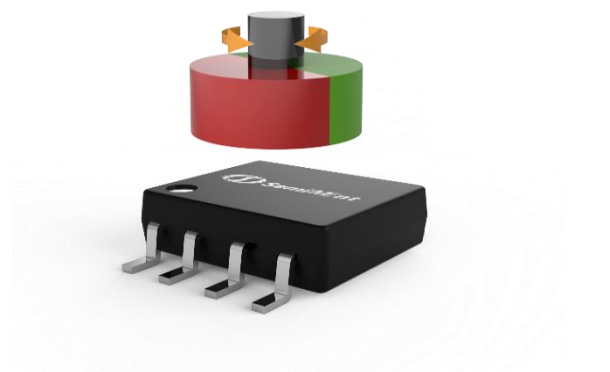

Fig.1 Schematic diagram of the work

CONTENTS

1. Features	1	10. Block Diagram	12
2. Applications	1	11. Output Format	13
3. Description	1	11.1. ABZ/PWM output	13
4. Pin Description	3	11.2. SPI output	15
5. Ordering Information	4	12. Power supply connection method	17
6. Absolute Maximum Ratings	5	12.1. Application circuit connection(5V)	17
7. ESD Protection	5	12.2. Application circuit connection(3.3V)	17
8. Operating Characteristics	6	13. Package Information DC	18
Operating Characteristics (Continued)	7	14. Packing Information	19
Operating Characteristics (Continued)	8	14. Revision History	20
9. Register Description	9		

4. Pin Description

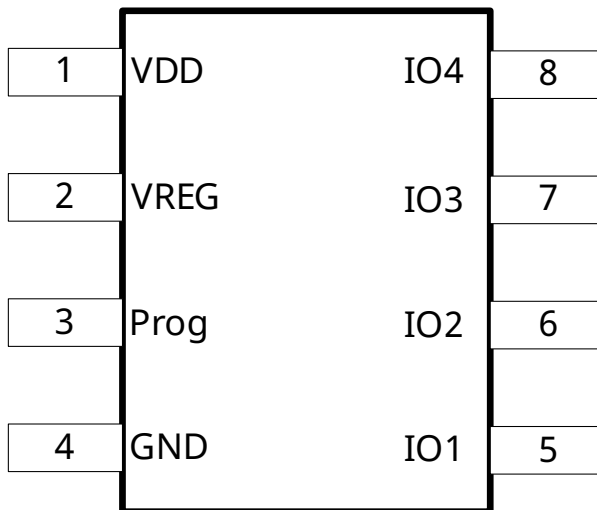

Fig.2 SC6021X Pin Description

Pin		Type	Pin function description
Name	No.		
VDD	1	PWR	Chip power supply port
VREG	2	PWR	The high-voltage LDO output inside the chip is connected to an external 100nF decoupling capacitor
Prog	3	Program	Program debug pin Program debug pin
GND	4	Ground	Chip Ground
IO1	5	In/Out	SPI mode: CSN, SPI communication enables input signal
			ABZ/PWM mode: A-channel incremental signal output/line-saving mode PWM output
			SIN/COS mode: COSP, cosine signal positive output
IO2	6	In/Out	SPI mode: SCK, SPI communication clock input signal
			ABZ/PWM mode: B-channel incremental signal output
			SIN/COS mode: COSN, negative output of cosine signal
IO3	7	In/Out	SPI mode: MOSI, SPI communication data slave signal input
			ABZ/PWM mode: Z-channel incremental signal output
			SIN/COS mode: SINP, positive output of sine signal
IO4	8	In/Out	SPI mode: MISO, SPI communication data slave signal output
			ABZ/PWM mode: PWM absolute angular output
			SIN/COS mode: SINN, negative output of sinusoidal signal

5. Ordering Information

Ordering Information	Mark	Option	Output	Ambient(°C)	Package	Pack	Amount
SC60214DC-1024-TR	60214	1024	ABZ+PWM	-40~150	SOP8	Tape&Reel	4000 Pcs/Reel
SC60214DC-256-TR	60214	256	ABZ+PWM	-40~150	SOP8	Tape&Reel	4000 Pcs/Reel
SC60214DC-50-TR	60214	50	ABZ+PWM	-40~150	SOP8	Tape&Reel	4000 Pcs/Reel
SC60218DC-TR	60214	-	SPI	-40~150	SOP8	Tape&Reel	4000 Pcs/Reel

Ordering Information Format

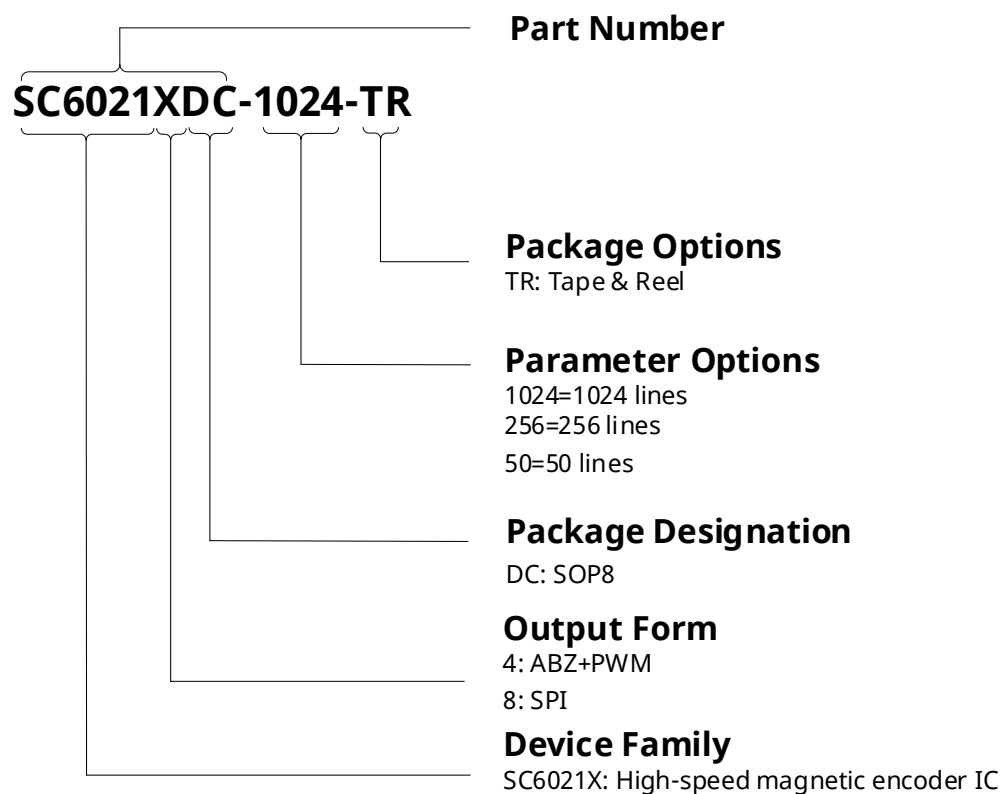

6. Absolute Maximum Ratings

Symbol	Parameter	Test Conditions	Min.	Max.	Unit
VDD	Power supply end withstand voltage		-18	24	V
VREG	Voltage rating of the voltage stabilizing terminal		-0.5	6.5	V
Prog	Programming feet		-0.5	6.5	V
IO1/2/3/4	Output withstand voltage		-0.5	24	V
T _A	Operating temperature		-40	160	°C
T _{STG}	Storage temperature		-65	175	°C
T _{J(max)}	Maximum junction temperature		-55	165	°C

Note:
Stresses above those listed here may cause permanent damage to the device. Prolonged exposure to absolute maximum ratings may affect the reliability of the device.

7. ESD Protection

Symbol	Parameter	Test Conditions	Min.	Max.	Unit
V _{ESD}	HBM	Human failure model, refer to ANSI/ESDA/JEDEC-001 standard	-4	4	kV
	CDM	Device failure model, refer to ANSI/ESDA/JEDEC-002 standard	-750	750	V

8. Operating Characteristics

Operating temperature range ($V_{DD}=5.0V$, unless otherwise noted) ⁽¹⁾

Symbol	Parameter	Test Conditions	Min.	Typ.	Max.	Unit
Electrical Characteristics						
V_{DD_5V}	5V application operating voltage	Refer to the 5V application circuit connection	4.5	5.0	5.5	V
$V_{DD_3.3V}$	3.3V application operating voltage	Refer to the 3.3V application circuit connection	3.0	3.3	3.6	V
I_{DD_5V}	5V application current	$V_{DD}=5.0V$	-	8.0	12	mA
$I_{DD_3.3V}$	3.3V application current	$V_{DD}=3.3V$	-	7.0	11	mA
V_{REG}	5V operation, V_{REG} pin voltage	$C_{REG}=100nF$	3.7	4.0	4.3	V
C_{REG}	V_{REG} pin decoupling capacitors		47	100	470	nF
$PSRR_{VREG}$	Power supply rejection ratio	1K-1M				dB
V_{OVP}	Overshoot diagnoses the on-voltage voltage	$V_{DD}>8V$	6.5	7.0	7.5	V
V_{OVP_HYS}	Overshoot diagnoses hysteresis voltage		0.2	0.5	0.8	V
V_{UVR}	Undervoltage diagnostic on-voltage		3.4	3.7	4.3	V
V_{UVR_HYS}	Undervoltage diagnostics hysteresis voltage		0.1	0.3	0.5	V
Magnetic field input characteristics						
D_{MAG}	Radial magnetized magnet diameter		4.0	6.0	8.0	mm
T_{MAG}	Radial magnetizing magnet thickness		-	2.5	-	mm
A_{DIS}	Magnet and chip surface distance		1.0	1.5	2.0	mm
H_{EXT}	Magnetic field strength range		20	30	60	mT
Rpm	Magnet speed		-	-	200,000	rpm
X_{DIS}	Magnet and chip center deviation		-	-	0.2	mm
SIN/COS analog output						
V_{PP5V}	5V applies sine and cosine output amplitude	$V_{DD}=5.0V, H_{EXT}=27mT$	1.0	2.0	3.8	Vpp
$V_{PP3.3V}$	3.3V applies sine and cosine output amplitude	$V_{DD}=3.3V, H_{EXT}=27mT$	1.0	1.8	2.6	Vpp
V_{DC}	Sine and Cosine DC level		40	50	60	% V_{DD}
OFF_{VPP}	Sine and Cosine output amplitude deviation		-10	0.0	10	mV
OFF_{VDC}	Sine Cosine DC level deviation		-20	0.0	20	mV
R_{LOAD}	Sine and Cosine output pull up resistor		4.7	-	470	k Ω
C_{LOAD}	Sine and Cosine output load capacitors	Directly connected to the output port	-	-	100	pF
T_{DELAY}	Sine and Cosine output signal is delayed		-	7	-	μs

Operating Characteristics (Continued)

Symbol	Parameter	Test Conditions	Min.	Typ.	Max.	Unit
Diagnostic function						
Dsat_lo	Proactive diagnostic output levels	Pull down Resistor: $R \geq 4.7k\Omega$	-	0.5	1	%V _{DD}
		Pull up Resistor: $R \geq 4.7k\Omega$	-	98	100	%V _{DD}
BV _{SS} PD	Passive Diagnostic Output Level (Open)	V _{SS} open circuit, pull-down resistor, 4.7 k $\Omega \leq R \leq 47k\Omega$	-	0	3	%V _{DD}
BV _{SS} PU		V _{SS} open circuit, pull-up resistor, 4.7 k $\Omega \leq R \leq 47k\Omega$	97	98	-	%V _{DD}
BV _{DD} PD		V _{DD} open circuit, pull-down resistor, 4.7 k $\Omega \leq R \leq 47k\Omega$	-	0	1	%V _{DD}
BV _{DD} PU		V _{DD} open circuit, pull-up resistor, 4.7 k $\Omega \leq R \leq 47k\Omega$	96.5	98	-	%V _{DD}
°C	Over-temperature protection		-	170	-	°C
I _{OCP}	Overcurrent protection		-		30	mA
A/D conversion characteristics						
R _{ES(SD)}	Sigma/Delta modulation resolution		-	14	-	Bit
T _(ON)	Startup time		-	-	5	ms
ABZ/PWM output characteristics						
F _{PWM}	PWM frequency (default)		976	1000	1024	Hz
F _{PWM(OPT)}	PWM frequency (optional)		232	244	256	Hz
R _{ES(AB)}	AB output line count	24, 50, 256, 1024 lines	24	-	1024	lines
Z _{WIDTH}	Z zero width	1/4T, 1T	1	4	-	LSB
Rpm	Rotate speed	REG_rpm=0	-	50000	-	rpm
	Rotate speed	REG_rpm=1	-	200000	-	rpm
IO digital port electrical characteristics						
V _{THI}	Enter a high level threshold		-	-	2.0	V
V _{TLO}	Enter a low level threshold		0.8	-	-	V
V _{SHI}	Output high voltage	4mA pull-down current	V _{DD} -0.5	-	-	V
V _{SLO}	Output low voltage	4mA pull-up current	-	-	0.5	V
V _{IH}	Input high level		0.5*V _{DD}	-	-	V
V _{OL}	Input low level		-	-	0.2*V _{DD}	V
V _{OH}	Output high level		0.8*V _{DD}	-	-	V
I _{SHI}	Outputs high-level short-to-ground current	V _{DD} =3.3V	-	-	30	mA
I _{SLO}	Outputs a low-level short-circuit to the supply current	V _{DD} =3.3V	-	-	30	mA

Operating Characteristics (Continued)

SPI communication time parameters						
T_{CSN}	CSN signal setup time		100	-	-	ns
T_{SCKH}	SCK high level time		80	-	-	ns
T_{SCKL}	SCK low level time		80	-	-	ns
T_{SCK}	SCK time period		160	-	-	ns

9. Register Description

EPROM Parameter Analysis Table

Page	Row	bit7	bit6	bit5	bit4	bit3	bit2	bit1	bit0	
0	0	DP1EN<1:0>		DP1<13:8>						
	1	DP1<7:0>								
	2	DP2EN<1:0>		DP2<13:8>						
	3	DP2<7:0>								
	4	DP3EN<1:0>		DP3<13:8>						
	5	DP3<7:0>								
	6	TRIMBG<2:0>				TRIMOSC<4:0>				
	7	DIR	CLK_SLOW	OUTMOD1:0>		V3P3EN	VOSEN	OTPEN	OVPEN	
	8	UVLOEN	VOSX2	G2<2:0>			G1<2:0>			
	9	ABZEDG<1:0>		ABZ_HYS<1:0>		ABZWID<1:0>		ABZLINE<2:1>		
	A	ABZLINE<0>	PWMCTRL	PWMPOL	PWMT	PWMMS	-	PID_FILTER_SEL		
	B	VOS_SIN<7:0>								
	C	VOS_COS<7:0>								
	D	-	-	-	-	-	-	-	-	
	E	-	-	-	-	-	-	-	-	
F	-	-	-	-	-	-	-	-		

EPROM Parameter Information

Symbol	BITS	ADDR	Type	Description
DP1EN<1:0>	2	0x00[7:6]	r/w	1st zero-point calibration enable bits
DP1	14	0x00[5:0]+0x01[7:0]	r/w	Zero position information; set current position as zero point
DP2EN<1:0>	2	0x00[7:6]	r/w	
DP2	14	0x00[5:0]+0x03[7:0]	r/w	Zero position information; set current position as zero point
DP3EN<1:0>	2	0x04[7:6]	r/w	3rd zero-point calibration enable bits
DP3	14	0x04[5:0]+0x05[7:0]	r/w	Zero position information; set current position as zero point
TRIMBG	3	0x06[7:5]	r/w	Internal bandgap voltage trimming
TRIMOSC	5	0x06[4:0]	r/w	Internal oscillator frequency trimming
DIR	1	0x07[7]	r/w	Rotation direction configuration: 0: Clockwise: A leads B; Counterclockwise: B leads A; 1: Clockwise: B leads A; Counterclockwise: A leads B;
CLK_SLOW	1	0x07[6]	r/w	ADC sampling clock frequency: 0: 8 MHz; 1: 16 MHz;
OUTMOD	2	0x07[5:4]	r/w	Output mode configuration: 0: SPI mode; 1: ABZ + PWM mode; 2: Analog sine-cosine output mode; 3: SPI mode;
V3P3EN	1	0x07[3]	r/w	3.3V application flag
VOSEN	1	0x07[2]	r/w	Internal offset cancellation enable
OTPEN	1	0x07[1]	r/w	Over-temperature protection: 0: OTP enabled; 1: OTP disabled;
OVPEN	1	0x07[0]	r/w	Over-voltage protection: 0: OVP enabled; 1: OVP disabled;
UVLOEN	1	0x08[7]	r/w	Under-voltage lockout protection: 0: UVLO enabled; 1: UVLO disabled;
VOSX2	1	0x08[6]	r/w	VOS compensation range: 0: ±5.2 mV; 1: ±2.6 mV;

G2<2:0>	3	0x08[5:3]	r/w	2nd stage gain adjustment: 6.06 ~ 21.93 ×1.2
G3<2:0>	3	0x08[2:0]	r/w	3rd stage gain adjustment: 0.81 ~ 1.51 ×1.1
ABZEDG<1:0>	2	0x09[7:6]	r/w	Z pulse and AB signal edge alignment adjustment: 0: Z rising edge aligns with A rising edge; 1: Z rising edge aligns with B rising edge; 2: Z rising edge aligns with A falling edge; 3: Z rising edge aligns with B falling edge;
ABZHYS	2	0x09[5:4]	r/w	Hysteresis setting for ABZ signals: 0: 0.25T 1: 0.5T 2: 0.75T 3: 1T
ABZWID	2	0x09[3:2]	r/w	Z pulse width setting for ABZ signals: 0: 0.25T 1: 0.5T 2: 180° 3: 1*T
ABZLINE	3	0x09[2:0]+ 0x0A[7]	r/w	Lines per revolution configuration for ABZ: 0: 12 lines 1: 24 lines 2: 50 lines 3: 128 lines 4: 256 lines 5: 512 lines 6: 2048 lines 7: 1024 lines
PWMCTRL	1	0x0A[6]	r/w	0: PWM flag output; 1: Normal PWM output;
PWMPOL	1	0x0A[5]	r/w	PWM polarity control: 0: PWM flag output; 1: Normal PWM output;
PWMT	1	0x0A[4]	r/w	PWM output frequency: 0: 250 Hz 1: 1000 Hz;
VOS_SIN	8	0x0B[7:0]	r/w	Offset adjustment for SIN channel
VOS_COS	8	0x0C[7:0]	r/w	Offset adjustment for COS channel

10. Block Diagram

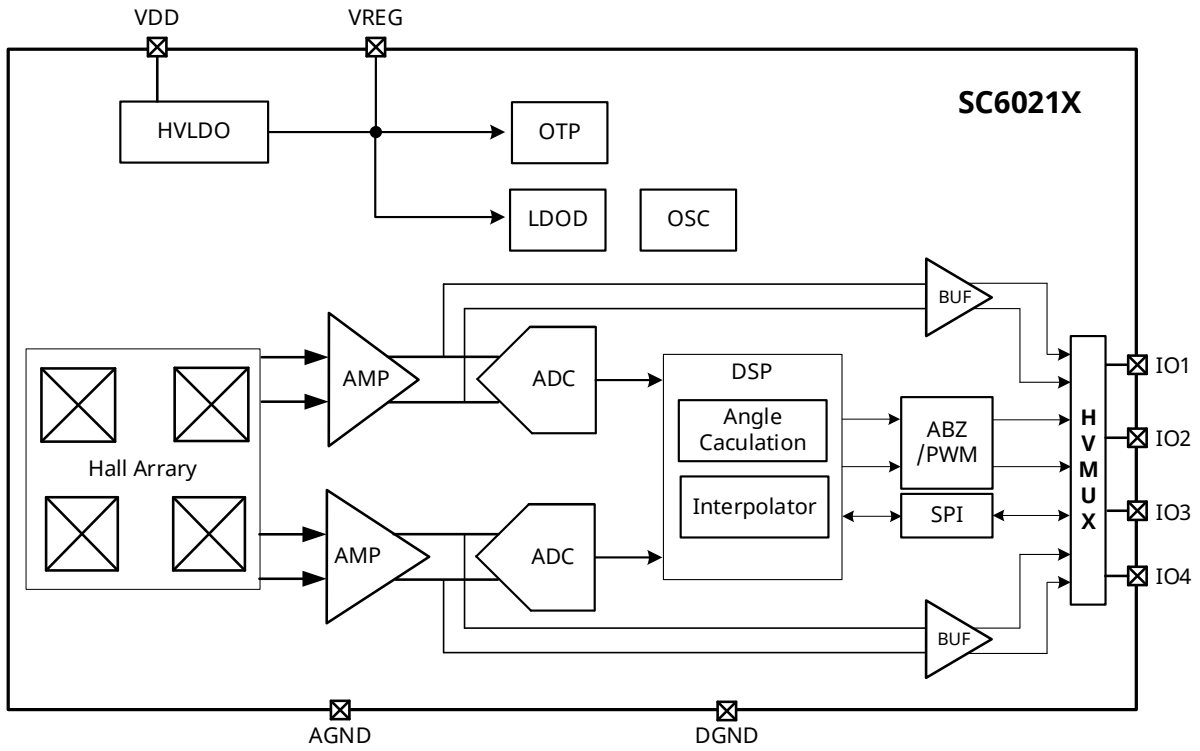

Fig.3 Block Diagram

11. Output Format

11.1. ABZ/PWM output

Typical application diagram

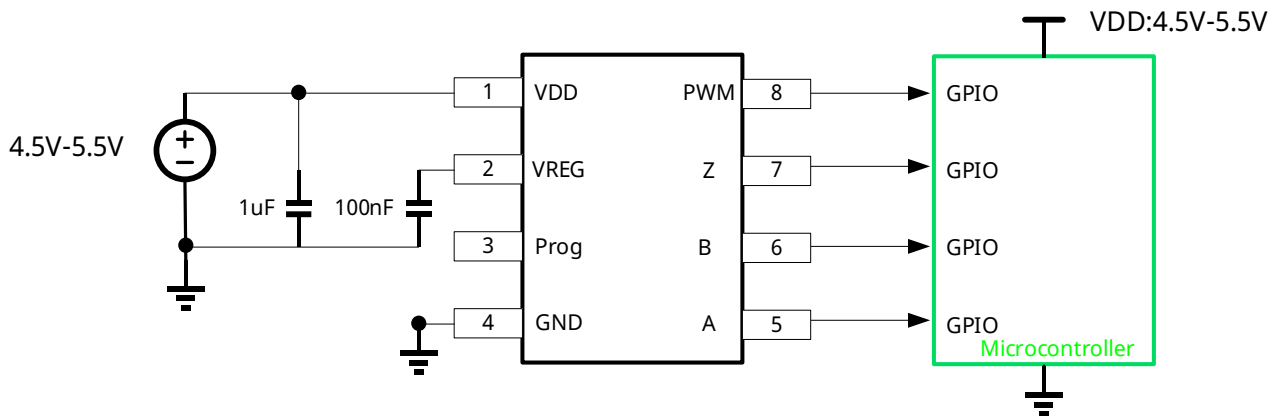

Fig.4 Incremental output application diagram

Description of Prog function:

When the motor is phase-locked at the zero position, short-circuit the Prog pin to the power supply for 2 seconds to achieve zero adjustment of the encoder chip, and program the current position as the encoder zero position.

ABZ output waveform diagram

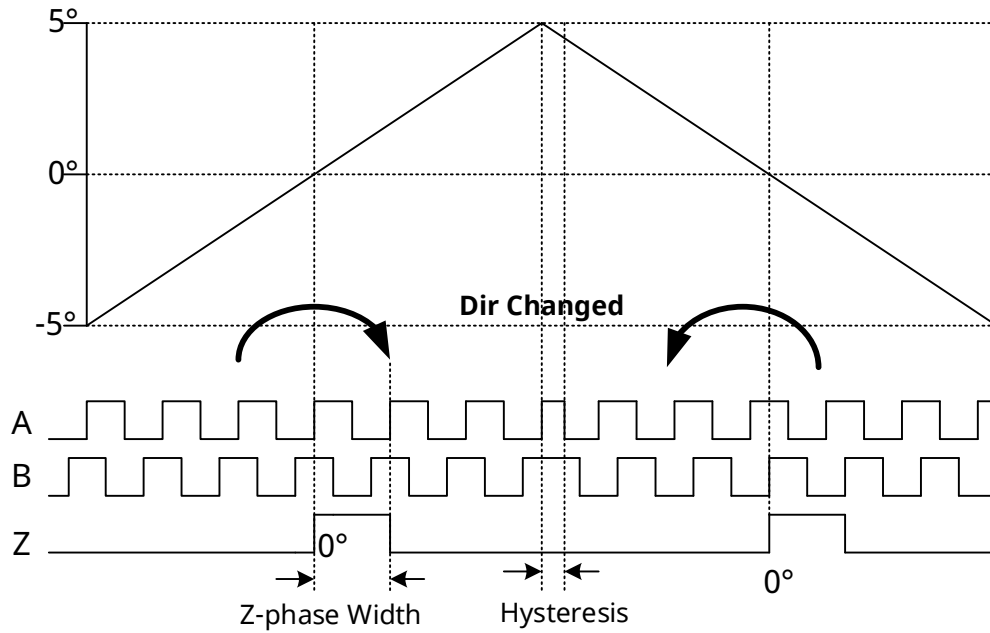

Fig.5 Incremental output waveform diagram

PWM output waveform diagram

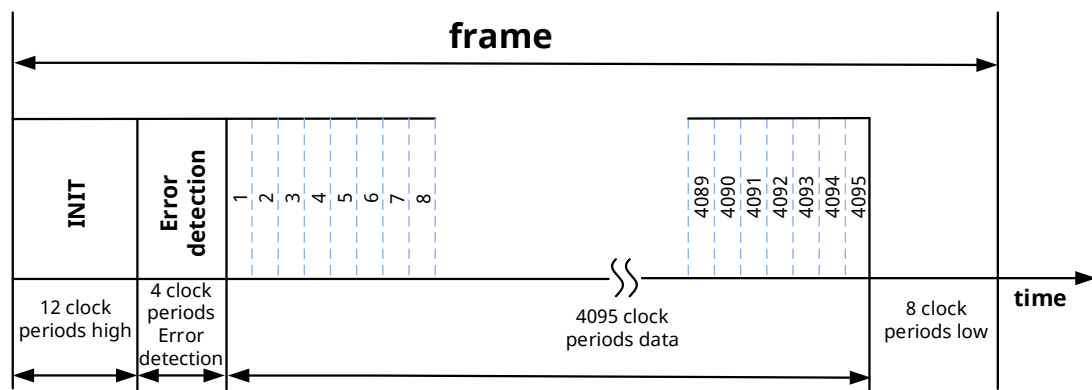

Fig.6 PWM output waveform diagram

11.2. SPI output

Typical application diagram

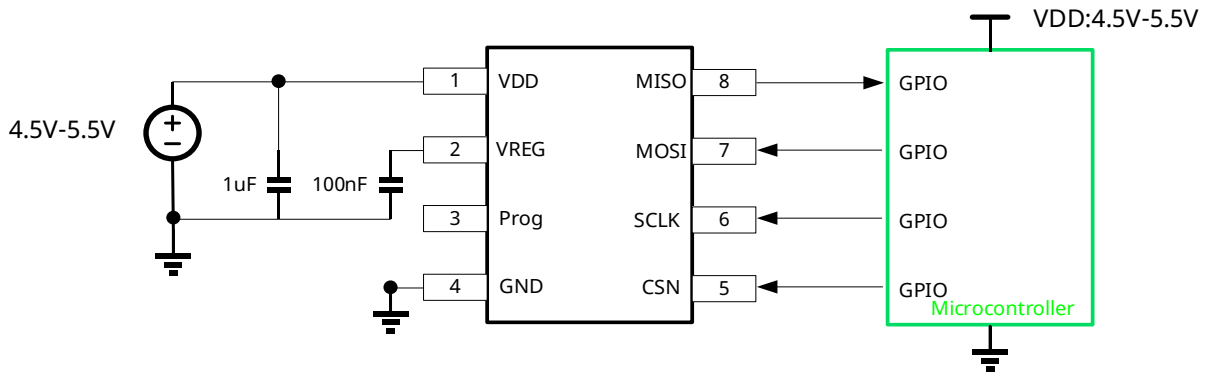

Fig. SPI application diagram

SPI output waveform diagram

Register read-write mode

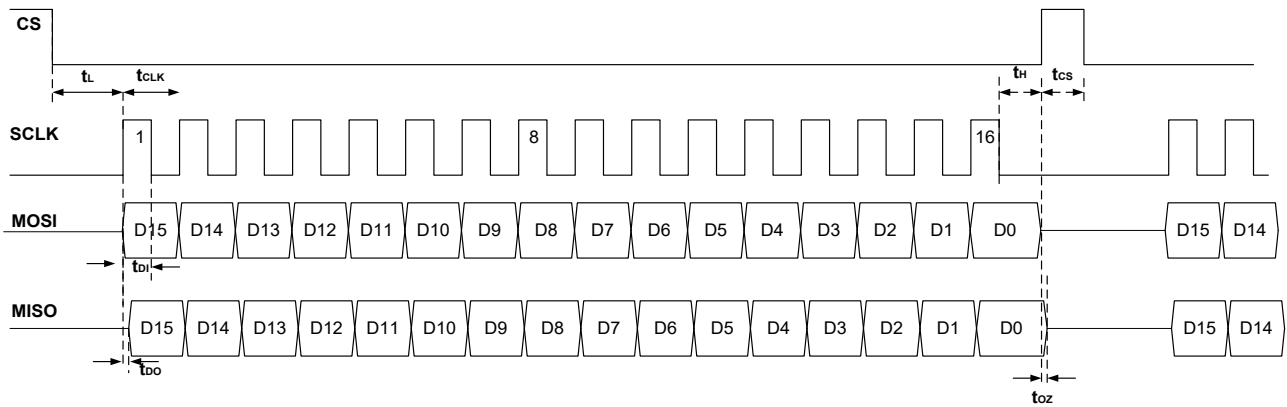

Fig.8 SPI register read-write mode diagram

Angle reading mode

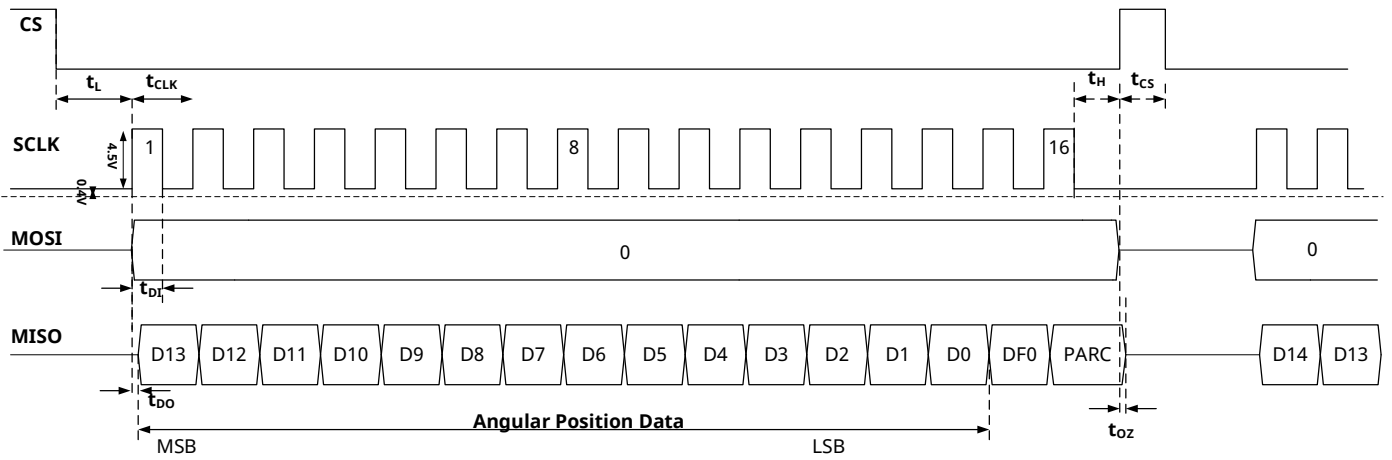

Fig.9 SPI angle reading mode diagram

12. Power supply connection method

12.1. Application circuit connection(5V)

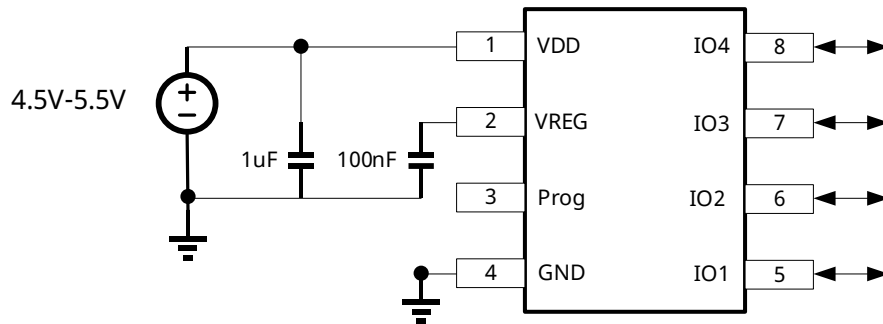

Fig.10 5V power supply circuit diagram

12.2. Application circuit connection(3.3V)

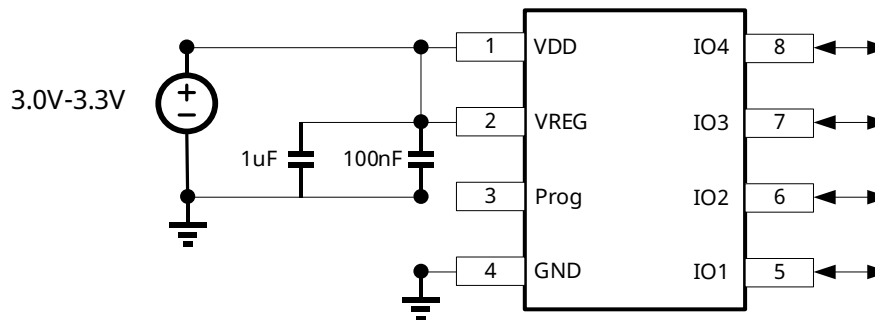
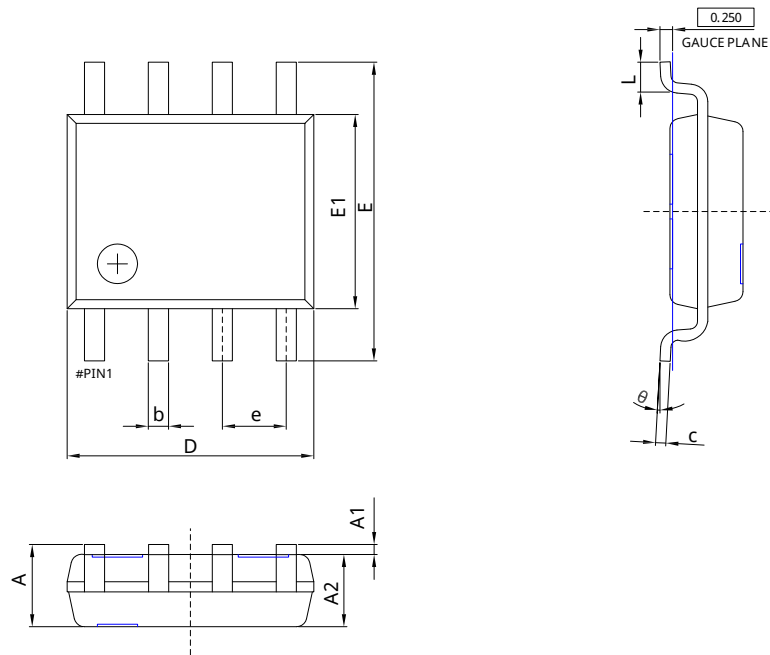

Fig.11 3.3V power supply circuit diagram

13. Package Information DC



Symbol	Dimensions In Millimeters		Dimensions In Inches	
	Min.	Max.	Min.	Max.
A	1.450	1.750	0.057	0.069
A1	0.100	0.250	0.004	0.010
A2	1.350	1.550	0.053	0.061
b	0.330	0.510	0.013	0.020
c	0.170	0.250	0.007	0.010
D	4.700	5.100	0.185	0.201
E	5.800	6.200	0.228	0.244
E1	3.800	4.000	0.150	0.157
e	1.270(BSC)		0.050(BSC)	
L	0.400	1.270	0.016	0.050
θ	0°	8°	0°	8°

Fig.12 SOP8 Package Dimension Drawing

14. Packing Information

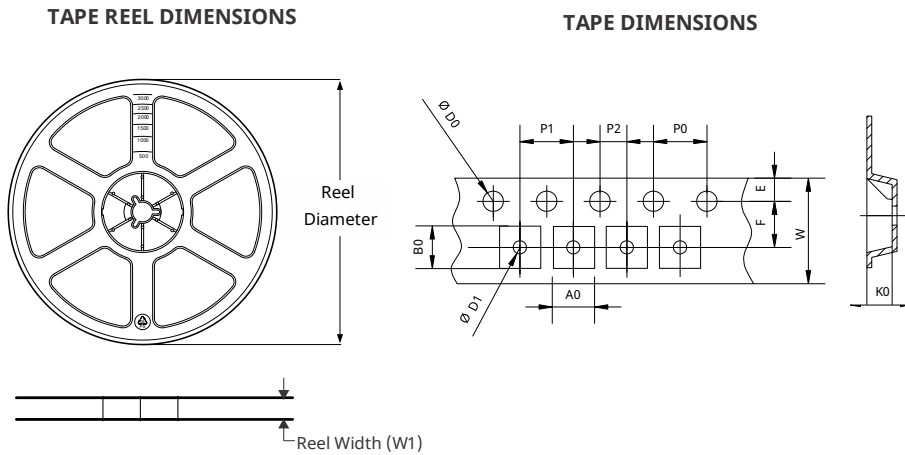

QUADRANT ASSIGNMENTS FOR PIN 1 ORIENTATION IN TAPE

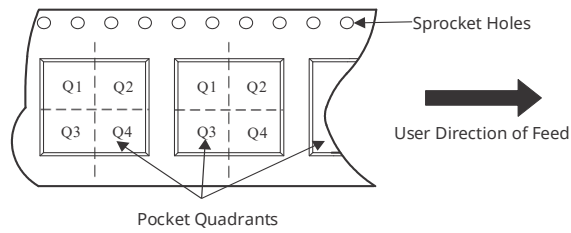

*All dimensions are nominal

Package Type	SPQ	Reel Diameter (mm)	Reel Width W1 (mm)	P0 (mm)	P1 (mm)	P2 (mm)	A0 (mm)	B0 (mm)	K0 (mm)	W (mm)	Pin1 Quadrant
SOP8	4000	330	13.0	4.00	8.00	2.00	6.40	5.40	2.10	12.00	Q1

Fig.13 SOP8 Tape&Reel dimensions

14. Revision History

Revision	Date	Description
Rev. V0.1	2025-07-31	Preliminary datasheet

Notice and Disclaimer

The information, data, and specifications set out in this document (the "Document") are provided "AS IS" and for reference purposes, they shall not be construed as any warranty or authorization, whether express or implied, including but not limited to warranties of accuracy, completeness, merchantability, fitness for a particular purpose, or non-infringement of any third party's intellectual property rights.

Users of this Document are solely responsible for the selection, use, and application of SEMIMENT products, as well as for ensuring the safety of such applications. Users shall comply with all applicable laws, regulations, and requirements related to the use of SEMIMENT products. Any application-related information or support that may be provided by SEMIMENT is for reference only and does not constitute any guarantee or liability.

The resources described in this Document are subject to change without notice. SEMIMENT grants permission to use these resources solely for the development of applications incorporating SEMIMENT products as described herein. Any other reproduction, distribution, or public display of these resources is prohibited without prior written consent. No license, express or implied, is granted under any SEMIMENT intellectual property rights or any third-party intellectual property rights.

You agree to defend, indemnify and hold harmless SEMIMENT and its representatives from and against any claims, damages, costs, losses, or liabilities arising from your use of these resources.

For the latest product information and technical support, please contact SEMIMENT (www.semiment.com).

Copyright © Semiment Technology Co.,Ltd