

---

## High Accuracy Programmable Linear Output Hall Effect Sensor

---

### 1. Features

- AEC-Q100 qualified
- Linear analog output voltage
- Programmable magnetic sensitivity
- Programmable output quiescent voltage
- Programmable temperature compensation
- Open-circuit, over- and under- voltage detection
- Operates from 4.5 to 5.5 V supply voltage
- Operates from -40 to 150°C temperature range
- Operate with static magnetic fields and dynamic Magnetic fields up to 2 kHz
- Total error < 2% over temperature range
- EMC and ESD optimized design
- TO-92U, SOP8 package

### 2. Applications

- Angle sensor
- Contact-less potentiometer
- Linear position sensing
- Magnetic field and current measurement

### 3. Description

The SC468X is a BiCMOS programmable linear Hall Effect sensor IC. The linear output voltage is proportional to the magnetic flux density. The output voltage is proportional to the supply voltage. All the parameters of the SC468X transfer characteristic are fully programmable. The  $V_Q$ , the sensitivity, the slope polarity, the output clamping levels, and the thermal sensitivity drift are all programmable in end-user applications. The part offers open-circuit, as well as over-voltage and under-voltage detection and individual programming of different sensors which are in parallel to the same supply voltage.

The SC468X is programmable by modulating the supply voltage. No additional programming pin is needed. The easy programmability allows a two-point calibration by adjusting the output voltage directly to the input signal. In addition, the temperature compensation of the Hall IC can be fit to all common magnetic materials by programming first and second order temperature coefficients of the Hall sensor sensitivity. This enables operation over the full temperature range with high accuracy.

The sensor is designed for hostile industrial and automotive applications and operates with typically 5 V supply voltage in the ambient temperature range from -40 up to 150°C. The SC468X is available in the very small leaded package TO-92U and SOP8.



Fig1: Package outline drawing

## CONTENTS

<b>1. Features</b> .....	<b>1</b>	<b>11. Typical Application</b> .....	<b>12</b>
<b>2. Applications</b> .....	<b>1</b>	<b>12. Transfer Function</b> .....	<b>12</b>
<b>3. Description</b> .....	<b>1</b>	<b>13. Package Information (SA)</b> .....	<b>13</b>
<b>4. Terminal Configuration</b> .....	<b>3</b>	<b>14. Package Information (DC)</b> .....	<b>14</b>
<b>5. Ordering Information</b> .....	<b>5</b>	<b>15. Package Information (DA)</b> .....	<b>15</b>
<b>6. Absolute Maximum Ratings</b> .....	<b>6</b>	<b>16. Revision History</b> .....	<b>16</b>
<b>7. ESD Protection</b> .....	<b>6</b>		
<b>8. Operating Characteristics</b> .....	<b>7</b>		
<b>9. Block Diagram</b> .....	<b>8</b>		
<b>10. Function Description</b> .....	<b>9</b>		

### 4. Terminal Configuration

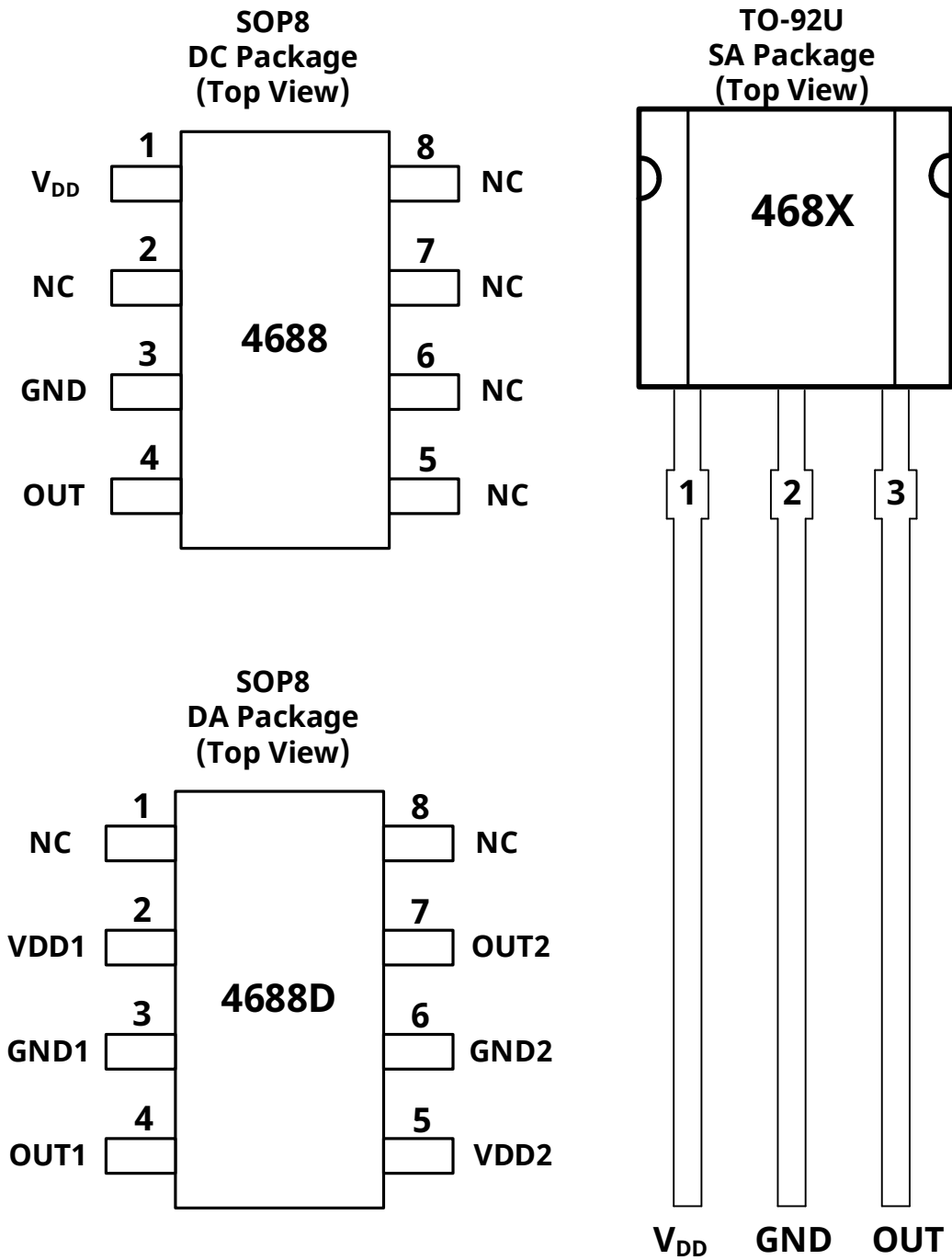

Fig2: Pin definition diagram

**DC Package Terminal Functions**

Terminal		Type	Description
Name	Number		
VDD	1	PWR	4.5V ~ 5.5V power supply
NC	2	Unconnected	-
GND	3	Ground	Ground terminal
OUT	4	Output	Output terminal

**DA Package Terminal Functions**

Terminal		Type	Description
Name	Number		
VDD1	2	HALL1 PWR	4.5V ~ 5.5V power supply
GND1	3	HALL1 Ground	Ground terminal
OUT1	4	HALL1 Output	Output terminal
VDD2	5	HALL2 PWR	4.5V ~ 5.5V power supply
GND2	6	HALL2 Ground	Ground terminal
OUT2	7	HALL2 Output	Output terminal
NC	1、8	Unconnected	-

**SA Package Terminal Functions**

Terminal		Type	Description
Name	Number		
VDD	1	PWR	4.5V ~ 5.5V power supply
GND	2	Ground	Ground terminal
OUT	3	Output	Output terminal

## 5. Ordering Information

Ordering Information	Option	Package	Ambient, (°C)	Mark	Pack	Amount
SC4688SA-BK-Q	-	TO-92U	-40 ~ 150	4688	Bulk	1000 pieces/bag
SC4689SA-BK-Q	-	TO-92U	-40 ~ 150	4689	Bulk	1000 pieces/bag
SC4688DC-TR-Q	-	SOP8	-40 ~ 150	4688	Reel	4000 pieces/reel
SC4688DC-DUAL-TR-Q	DUAL	SOP8	-40 ~ 150	4688D	Reel	4000 pieces/reel

### Ordering Information Format

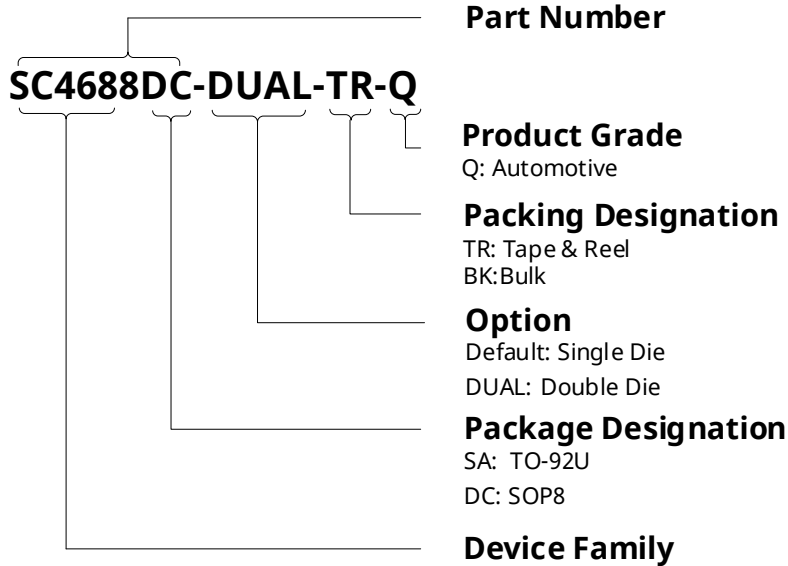

## 6. Absolute Maximum Ratings

Symbol	Parameter	Test Conditions	Rating	Unit
V <sub>DD</sub>	Forward Supply Voltage	< 96 hours	8.5	V
		< 1 hour	16	V
V <sub>RCC</sub>	Reverse Supply Voltage	< 96 hours	-8.5	V
		< 1 hour	-16	V
V <sub>OUT</sub>	Forward Output Voltage	< 96 hours	8.5	V
		< 1 hour	16	V
V <sub>ROUT</sub>	Reverse Output Voltage	-	-5	V
I <sub>OUT (source)</sub>	Output Source Current	V <sub>OUT</sub> to GND	10	mA
I <sub>OUT (sink)</sub>	Output Sink Current	V <sub>DD</sub> to V <sub>OUT</sub>	10	mA
-	EEPROM Write Cycles	-	100	cycle
T <sub>A</sub>	Operating Ambient Temperature	-	-40--150	°C
T <sub>STG</sub>	Storage Temperature	-	-65--165	°C
T <sub>J(max)</sub>	Maximum Junction Temperature	-	165	°C

**Note:**

Stresses above those listed here may cause permanent damage to the device. Exposure to absolute maximum rating conditions for extended periods may affect device reliability.

## 7. ESD Protection

Symbol	Parameter	Test conditions	Min.	Max.	Units
V <sub>ESD_HBM</sub>	HBM	Refer to AEC-Q100-002E HBM standard, R=1.5kΩ, C=100pF	-4	+4	KV
V <sub>ESD_CDM</sub>	CDM	Refer to AEC-Q100-011C CDM standard	-750	750	V

## 8. Operating Characteristics

Valid through the full operating temperature range, VDD=5V, as not otherwise specified in conditions

Symbol	Parameter	Test Conditions	Min.	Typ.	Max.	Unit
<b>Electrical Characteristics</b>						
V <sub>DD</sub>	Supply Voltage	-	4.5	5	5.5	V
I <sub>DD</sub>	Supply Current	Over temperature range	-	7.5	10	mA
V <sub>DDZ</sub>	Overshoot Protection at Supply	I <sub>DD</sub> =25mA, T <sub>J</sub> =25 °, t=20ms	-	17.5	20	V
V <sub>OZ</sub>	Overshoot Protection at Output	I <sub>O</sub> =10mA, T <sub>J</sub> =25 °, t=20ms	-	17	19.5	V
I <sub>OUT</sub>	Output Current	-	-1	-	1	mA
R <sub>L</sub>	Load Resistor	-	4.5	-	-	kΩ
C <sub>L</sub>	Load Capacitance	-	0.33	10	1000	nF
E <sub>A</sub>	Accuracy Error over all	R <sub>L</sub> =4.7kΩ(% of supply voltage)	-2	0	2	%
INL	Non-Linearity of Output Voltage over Temp	% of supply voltage	-1	0	1	%
ΔV <sub>OUTCL</sub>	Accuracy of Output Voltage at Clamping Low Voltage over Temp. Range	R <sub>L</sub> =4.7kΩ, VDD=5.0V	-45	0	45	mV
ΔV <sub>OUTCH</sub>	Accuracy of Output Voltage at Clamping High Voltage over Temp. Range	R <sub>L</sub> =4.7kΩ, VDD=5.0V	-45	0	45	mV
V <sub>OUTCH</sub>	Output High Voltage	VDD=5V, -1mA<I <sub>OUT</sub> <1mA	4.65	4.8	-	V
V <sub>OUTCL</sub>	Output Low Voltage	VDD=5V, -1mA<I <sub>OUT</sub> <1mA	-	0.2	0.4	V
tr(o)	Response Time of Out put	3dB filter frequency = 500Hz	-	1	2	ms
		3dB filter frequency = 1KHz	-	0.5	1	ms
t <sub>POD</sub>	Power-Up Time	C <sub>L</sub> =10nF, 90% of V <sub>out</sub>	1.5	1.7	1.9	ms
BW	Small Signal Bandwidth	BAC<10mT	2	-	-	kHz
V <sub>OUTn</sub>	Noise Output Voltage	magnetic range = 100mT	-	6	15	mV
<b>Open-Circuit Detection</b>						
V <sub>OUT</sub>	Output Voltage at open VDD Line	V <sub>DD</sub> =5V, R <sub>L</sub> =10k to GND	0	-	0.2	V
V <sub>OUT</sub>	Output Voltage at open GND Line	V <sub>DD</sub> =5V, R <sub>L</sub> =10k to VDD	4.7	4.8	5	V
<b>Under-voltage and Over-voltage Detection</b>						
V <sub>DD,UV</sub>	Under-voltage detection level	-	3.9	4.1	4.3	V
V <sub>DD,OV</sub>	Over-voltage detection level	-	7.0	8.7	10	V

## 9. Block Diagram

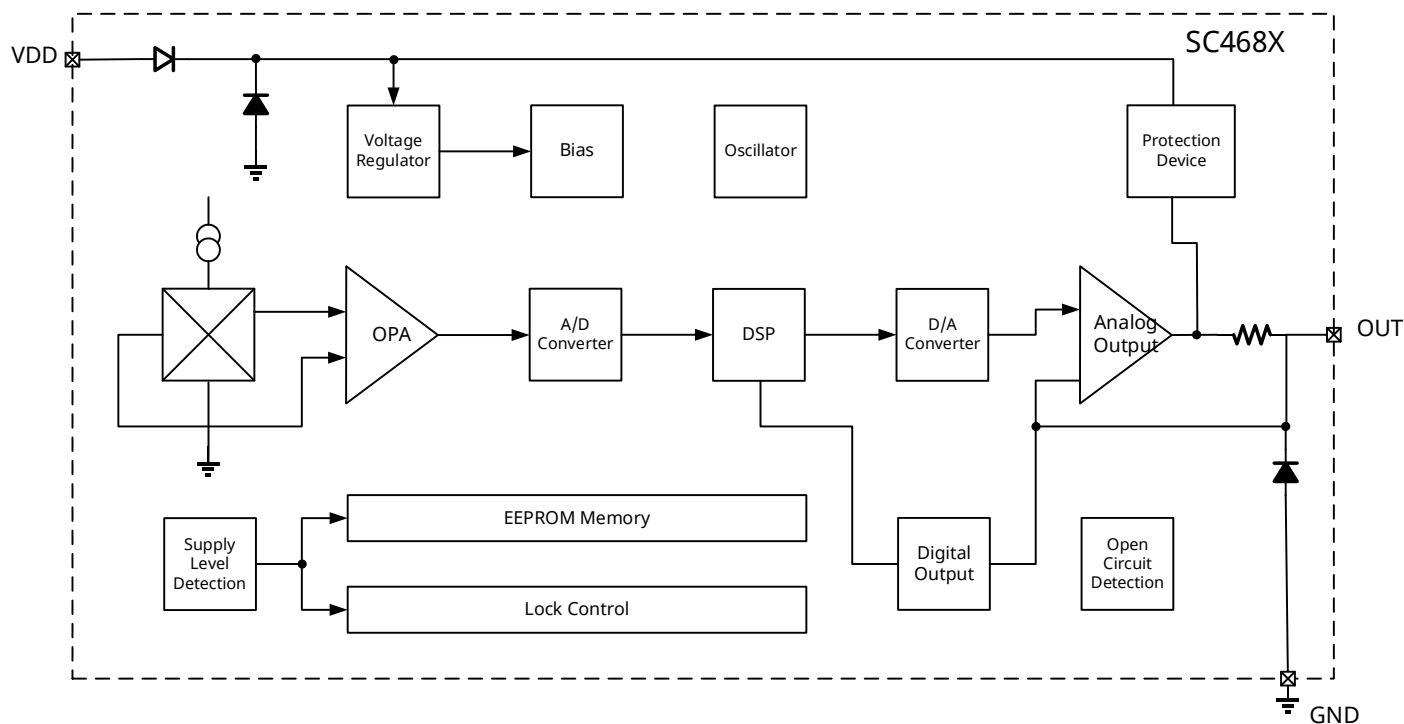

Fig3: Functional block diagram

## 10. Function Description

The SC468X is a monolithic integrated circuit which provides an output voltage proportional to the magnetic flux through the Hall plate and proportional to the supply voltage. The external magnetic field component perpendicular to the branded side of the package generates a Hall voltage. The Hall IC is sensitive to magnetic north and south polarity. This voltage is converted to a digital value, processed in the Digital Signal Processing Unit (DSP) according to the settings of the EEPROM, converted to an analog voltage with radiometric behavior, and stabilized by a push-pull output transistor stage. The LOCK register disables the programming of the EEPROM memory for all time. This register cannot be reset.

As long as the LOCK register is not set, the output characteristic can be adjusted by programming the EEPROM. The IC is addressed by modulating the supply voltage. In the supply voltage range from 4.5V up to 5.5V, the sensor generates an analog output voltage. After detecting a command, the sensor reads or writes the memory and answers with a digital signal on the output pin.

Several sensors (DU Package) in parallel to the same supply and ground line can be programmed individually. The selection of each sensor is done via its output pin.

The open-circuit detection provides a defined output voltage if the VDD or GND line is broken. Internal temperature compensation circuitry and the chip offset compensation enables operation over the full temperature range with minimal changes in accuracy and high offset stability. The circuitry also rejects offset shifts due to mechanical stress from the package. The non-volatile memory consists of redundant EEPROM cells. In addition, the sensor IC is equipped with devices for over-voltage and reverse-voltage protection at all pins.

### EEPROM Programming Information

The DSP is the main part of this sensor and performs the signal conditioning. The parameters for the DSP are stored in the EEPROM registers.

#### The EEPROM consists of three groups:

**Group 1** contains the registers for the adaption of the sensor to the magnetic system: MODE for selecting the magnetic field range and filter frequency, TC, TCSQ and TC-range for the temperature characteristics of the magnetic sensitivity.

**Group 2** contains the registers for defining the output characteristics: SENSITIVITY, VOQ, CLAMP-LOW, and CLAMP-HIGH. The output characteristic of the sensor is defined by these 4 parameters. The output voltage range can be clamped by setting the registers CLAMP-LOW and CLAMP-HIGH in order to enable failure detection (such as short-circuits to  $V_{DD}$  or GND and open connections).

**GROUP 3** contains the internal registers and LOCK for the locking of all registers. The internal registers are programmed and locked during production. These registers are used for oscillator frequency trimming, A/D converter offset compensations, and several other special settings.

An external magnetic field generates a Hall voltage on the Hall plate. The ADC converts the amplified positive or negative Hall voltage to a digital value. The digital signal is filtered in the internal low-pass filter and manipulated according to the settings stored in the EEPROM. The digital value after signal processing is readable in the D/A-READOUT register. Depending on the programmable magnetic range of the Hall IC, the operating range of the A/D converter is for -30mT----+30mT up to -100mT-----+100mT

## Range

The RANGE bits are bit 1 and 2 of the MODE register; they define the magnetic field range of the A/D converter.

Magnetic Field Range	Code
-30mT -- +30mT	00
-60mT -- +60mT	01
-80mT -- +80mT	10
-100mT -- +100mT	11

## TC Register

The sensor can compensate for linear temperature coefficients ranging from about -3100 ppm/k up to 1000ppm/k and quadratic coefficients from about -7ppm/K<sup>2</sup> to 2ppm/K<sup>2</sup>. The full TC range is separated in the following ranges:

TC-Range(ppm/k)	Code
-3100 to -1800	00
-1750 to -550	10
-550 to +450	01
+450 to +1000	11

## Sensitivity

The SENSITIVITY register contains the parameter for the multiplier in the DSP. The Sensitivity is programmable between -4 and 4. For  $V_{DD}=5V$ , the register can be changed in steps of 0.00049.

## VOQ

The VOQ register contains the parameter for the adder in the DSP.  $V_{OQ}$  is the output voltage without external magnetic field and programmable from  $-V_{DD}$  up to  $V_{DD}$ . For  $V_{DD} = 5V$  the register can be changed in steps of 4.9mV.

## Clamping Voltage

The output voltage range can be clamped in order to detect failures like short circuits to VDD or GND or an open circuit.

The CLAMP-LOW register contains the parameter for the lower limit. The lower clamping voltage is programmable between 0V and  $V_{DD}/2$ . For  $V_{DD} = 5V$ , the register can be changed in steps of 9.77mV.

The CLAMP-HIGH register contains the parameter for the upper limit. The upper clamping voltage is programmable between 0V and  $V_{DD}$ . For  $V_{DD} = 5V$ , the register can be changed in steps of 9.77mV.

## LOCKER

By setting the first bit of this 2-bit register, all registers will be locked and the sensor will no longer respond to any supply voltage modulation. This bit is active after the first power-off and power-on sequence after setting the LOCK bit.

*Warning:*

*this register cannot be reset!*

## 11. Typical Application

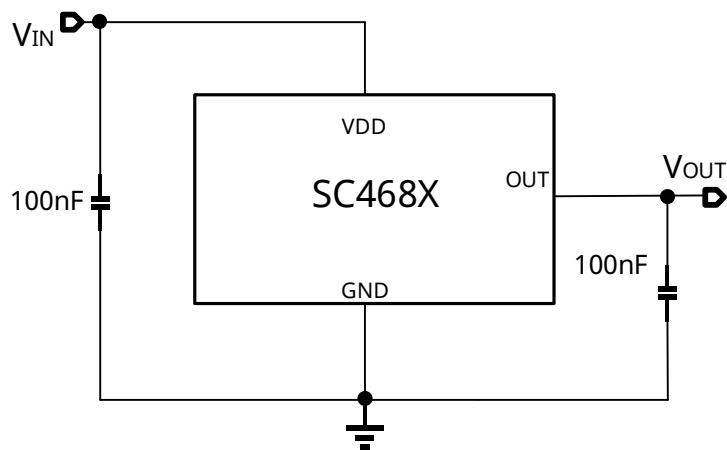

Fig4: Typical Application diagram

## 12. Transfer Function

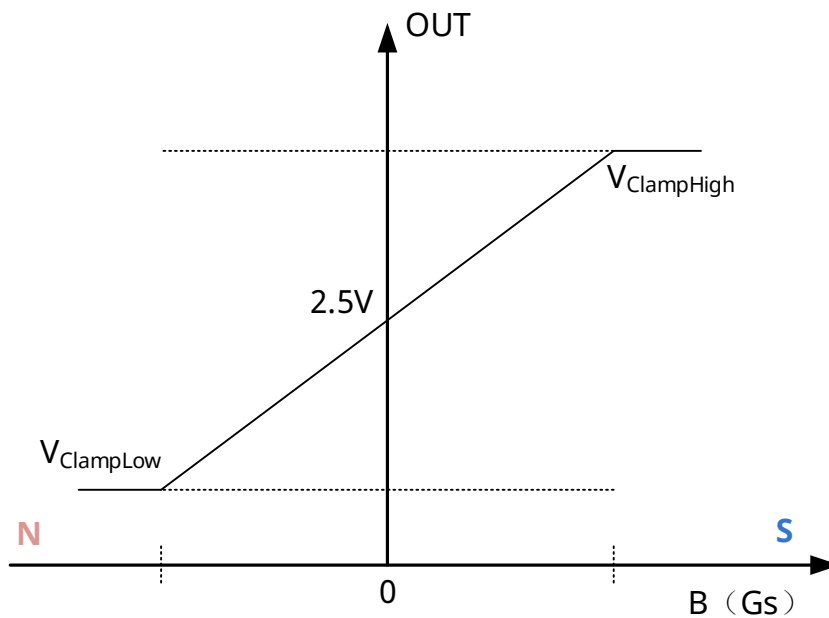

Fig5: Transfer Function diagram

### 13. Package Information (SA)

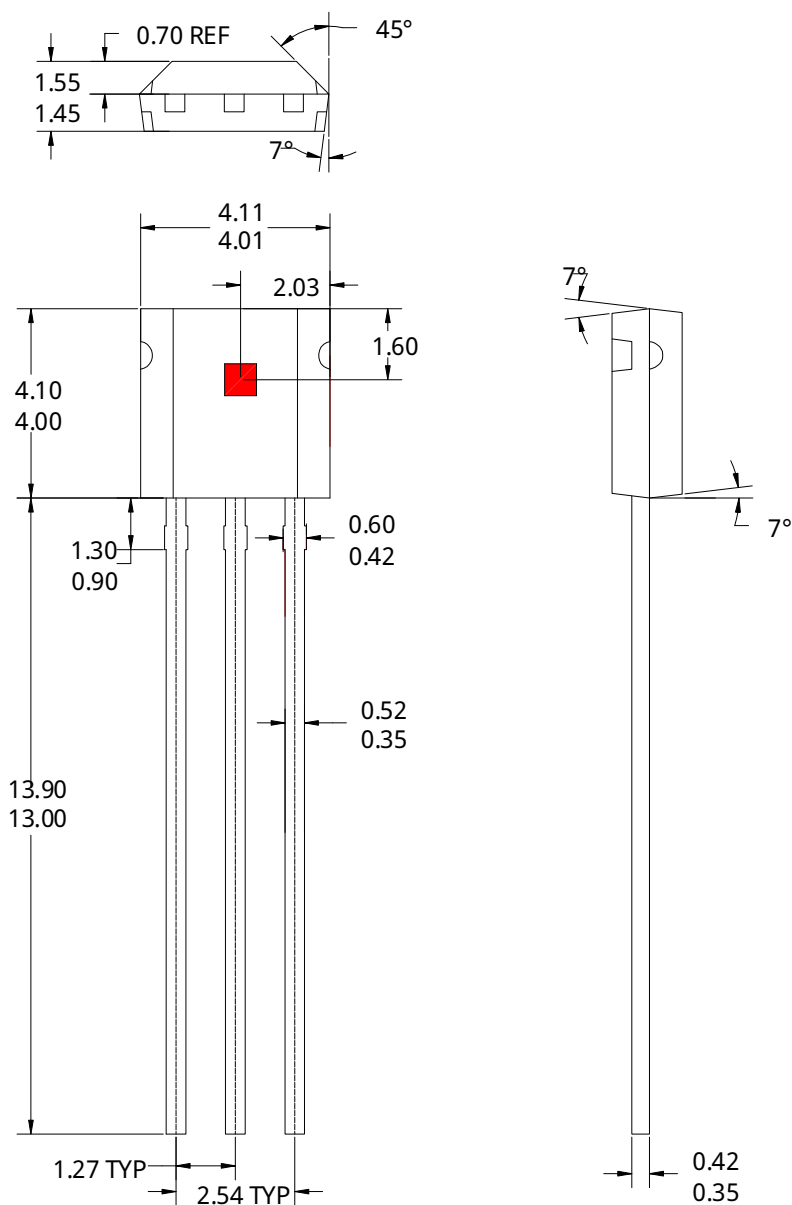
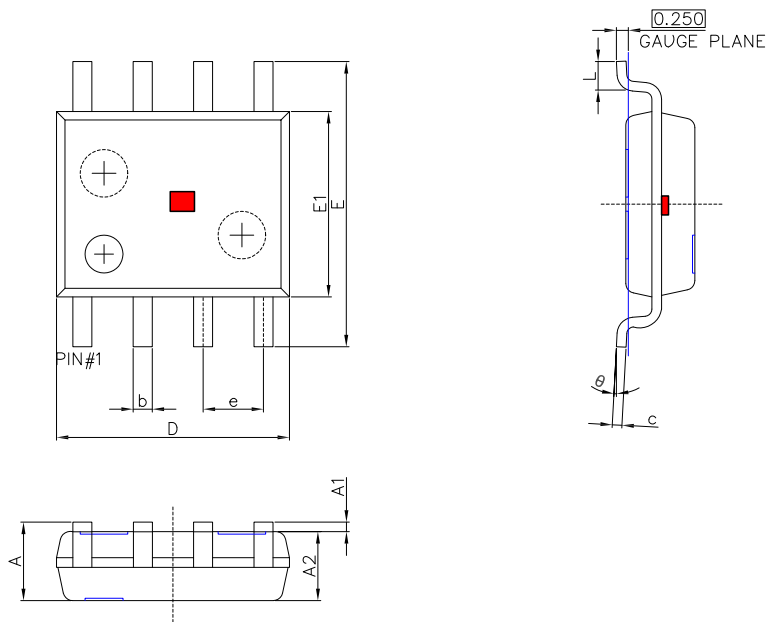

Fig6: Package Information "SA" diagram

Notes:

- A. All linear dimensions are in millimeters. Dimension and tolerancing per ASME Y14.5-1994
- B. Body dimension do not include mold flash
- C. This package complies to JEDEC MS-012 variation BA
- D. Red component is the Hall Plat

### 14. Package Information (DC)



Symbol	Dimensions In Millimeters		Dimensions In Inches	
	Min.	Max.	Min.	Max.
A	1.450	1.750	0.057	0.069
A1	0.100	0.250	0.004	0.010
A2	1.350	1.550	0.053	0.061
b	0.330	0.510	0.013	0.020
c	0.170	0.250	0.007	0.010
D	4.700	5.100	0.185	0.201
E	5.800	6.200	0.228	0.244
E1	3.800	4.000	0.150	0.157
e	1.270(BSC)		0.050(BSC)	
L	0.400	1.270	0.016	0.050
θ	0°	8°	0°	8°

Fig7: SOP-8 Package (Single Die) Shape and Dimension in millimeters

Notes:

- A. All linear dimensions are in millimeters. Dimension and tolerancing per ASME Y14.5-1994
- B. Body dimension do not include mold flash
- C. This package complies to JEDEC MS-012 variation BA
- D. Red component is the Hall Plat

## 15. Package Information (DA)

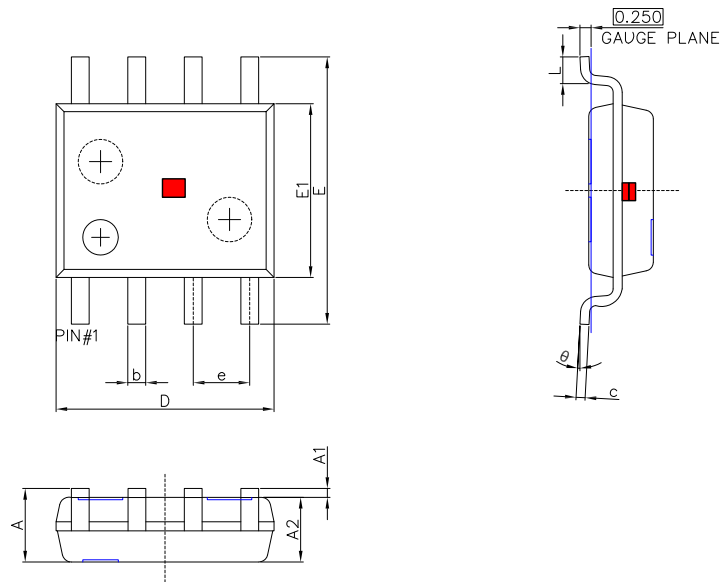

Symbol	Dimensions In Millimeters		Dimensions In Inches	
	Min.	Max.	Min.	Max.
A	1.450	1.750	0.057	0.069
A1	0.100	0.250	0.004	0.010
A2	1.350	1.550	0.053	0.061
b	0.330	0.510	0.013	0.020
c	0.170	0.250	0.007	0.010
D	4.700	5.100	0.185	0.201
E	5.800	6.200	0.228	0.244
E1	3.800	4.000	0.150	0.157
e	1.270(BSC)		0.050(BSC)	
L	0.400	1.270	0.016	0.050
θ	0°	8°	0°	8°

Fig8: SOP-8 Package (Double Die) Shape and Dimension in millimeters

Notes:

- A. All linear dimensions are in millimeters. Dimension and tolerancing per ASME Y14.5-1994
- B. Body dimension do not include mold flash
- C. This package complies to JEDEC MS-012 variation BA
- D. Red component is the Hall Plat

## 16. Revision History

Revision	Date	Description
Rev1.0	2018-11-04	Preliminary Datasheet
Rev1.1	2019-03-05	Add order information of SC4688DC
Rev2.4	2019-07-07	The final revision of old datasheet
Rev.A1.0	2020-11-09	Unified datasheet format
Rev.A1.1	2022-11-02	Change the SOP8 pin definition
Rev.A1.2	2023-03-09	Add order information of SC4689
Rev.A1.3	2023-08-10	Delete order information of SC4689DC
Rev.A1.4	2024-07-24	Update package information
Rev.A1.5	2024-08-07	Add package information of SC4688DA
Rev.A1.6	2025-02-10	Modify the order information